

HT152

● Features

- Combines high output GaAs IRED with high sensitive photodalington transistor.
- Non-contact detecting manner.
- Slit width(resolution): 1 mm

● Dimensions Unit:mm

Unless otherwise specified, the tolerances are $\pm 0.2\text{mm}$

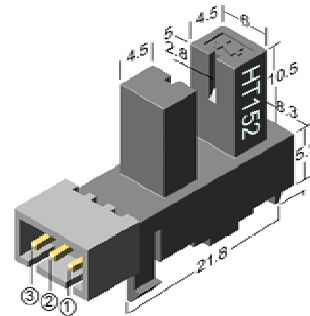

Internal Circuit

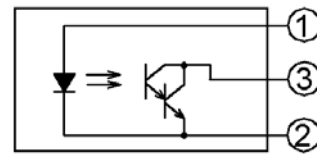

● Absolute Maximum Ratings(Ta=25°C)

Parameter		Symbol	Rating	Unit
Input	Forward Current	IF	50	mV
	Reverse Voltage	VR	6	V
	Power Dissipation	P	75	mW
Output	Collector-Emitter voltage	VCEO	25	V
	Emitter-Collector voltage	VECO	6	V
	Collector Power Dissipation	PC	50	mW
*Operating Temperature		Topr	-20~65	°C
Storage Temperature		Tstg	-30~75	°C
Soldering Temperature		Tsol	-	°C

*The special requirement could be met according to customer's request.

● Electro-Optical Characteristics (Ta=25°C)

Parameter		Symbol	Test Condition	Min.	Typ.	Max.	Unit
Input	Forward Voltage	VF	IF=20mA	-	1.25	1.5	V
	Reverse Current	IR	VR=3V	-	-	10	μ A
Output	Collector Dark Current	ICEO	VCE=20V	-	-	1	μ A
	Collector Light Current	IL	VCE=5V IF=8mA	4	-	-	mA
	Collector-Emitter Saturation Voltage	VCE(SAT)	IF=8 mA Ic=4mA	-	-	0.9	V
Transfer Characteristics	Response Time	RiseTime	Tr	IF=20mA VCE=5V	-	5	μ S
		FallTime	Tf	RC=100 Ω	-	5	μ S